

STANLEY BOSTITCH

Model P6C Series Plier

CAUTION: Read instructions carefully before operating plier, and save them for future reference.

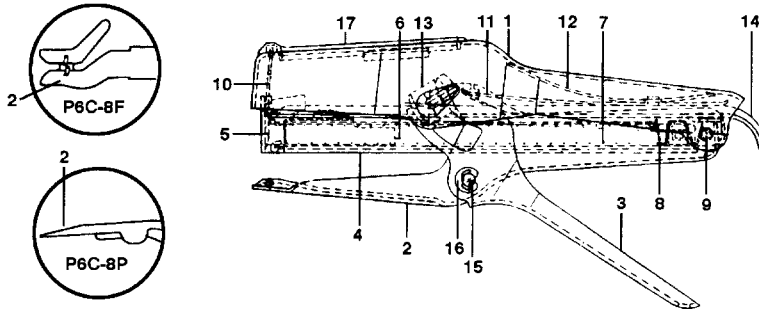

Item No.	Description	Part No.	Item No.	Description	Part No.
1	DRIVER ARM	100392	8	RETAINER	100400
2	CLINCHER ARM P6C	100393	9	PIVOT PIN	100401
2	CLINCHER ARM P6C-8P	100396	10	DRIVER P6C-8	100402
2	CLINCHER ARM P6C-8F	102482	10	DRIVER P6C-6	100403
3	OPERATING LEVER	100394	11	CLINCHER ARM SPRING	100404
4	MAGAZINE P6C-8	100537	12	MAGAZINE SPRING	100405
4	MAGAZINE P6C-6	100540	13	DRIVE BEARING	100406
5	CORE P6C-8	100538	14	MAGAZINE COVER	100407
5	CORE P6C-6	100541	15	LEVER PIN	100408
6	PUSHER	100399	16	E-RING	85018
7	PUSHER SPRING	P627	17	LOADING GUIDE	100409

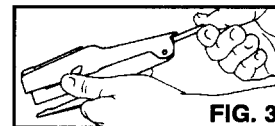
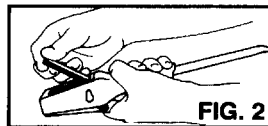
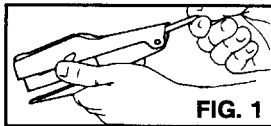

TO LOAD: Pull "up" and out until magazine cover is open as far as it will go. (See FIG.1). Squeeze plier closed and insert staple stick through loading guide, rear end first, as shown in FIG. 2. Let front end of stick drop in. Be sure it drops in completely. Push magazine cover closed as shown in FIG. 3, until you hear a "click" indicating that it is completely closed.

Staples Required: P6C-8 series use STCR50191/4 and 3/8
 P6C-6 series use STCR26191/4 and 3/8
 P6C-8P series use STCR50191/4 and 3/8
 P6C-8F series use STCR50191/4 and 3/8

WARNING: KEEP FINGERS AWAY FROM STAPLE DISCHARGE AREA WHEN OPERATING OR WHEN CLEARING A JAM. NOTE: P6C-8P POINTED BLADE - USE EXTRA CARE WHEN HANDLING.

TO CLEAR A JAM: Grasp plier as if ready to staple. Insert a pencil or similar object between clincher arm and magazine, away from staple discharge area. Operate plier once or twice to expel jammed staples. Do not pry with screwdriver or similar tool as damage to magazine may occur.

TO DISASSEMBLE: (Assembly is reverse) Remove lever pin and operating lever. Remove loading guide by squeezing in on sides. Remove magazine cover by disengaging front from pusher and then pulling it out. Squeeze driver tips together with pliers until disengaged from driver arm. Swing driver arm open. Remove drive bearings. Remove magazine spring from atop clincher arm spring. Disengage front tabs of clincher arm spring from clincher arm and remove clincher arm spring. Push retainer rear leg out from under magazine, and lift out assembly of core, pusher, pusher spring and retainer.

WARNING: DO NOT DISASSEMBLE CORE-ASSEMBLY, AS COMPRESSED PUSHER SPRING AND RETAINER MAY FLY OFF, CAUSING EYE INJURY.

STANLEY BOSTITCH

Stanley Fastening Systems
 East Greenwich, RI 02818