

MECHANICAL TOOL FOR STRAPPING**M4K-12****OPERATING INSTRUCTIONS**

Before using the tool, read operating instructions carefully

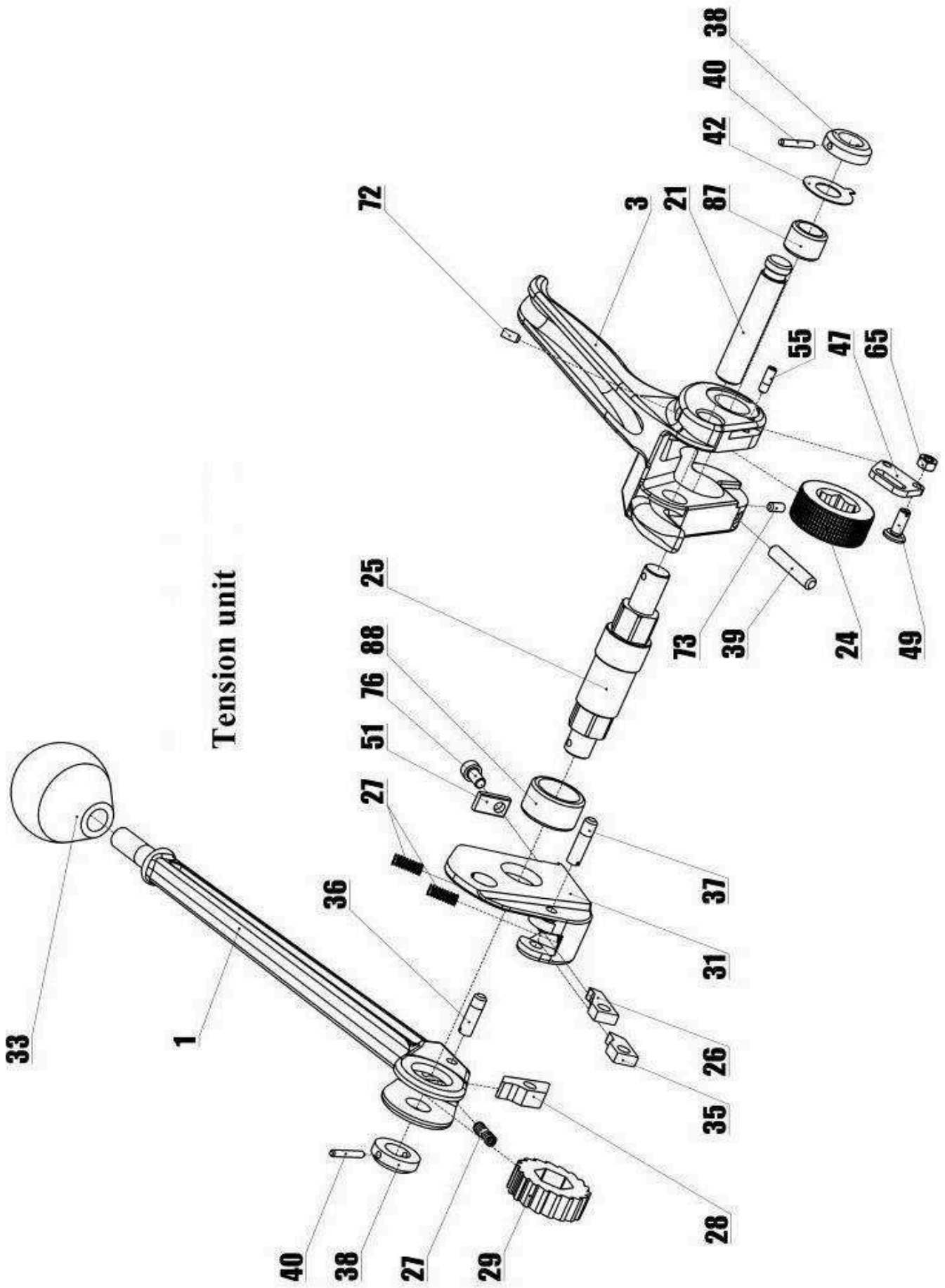

Cutting unit

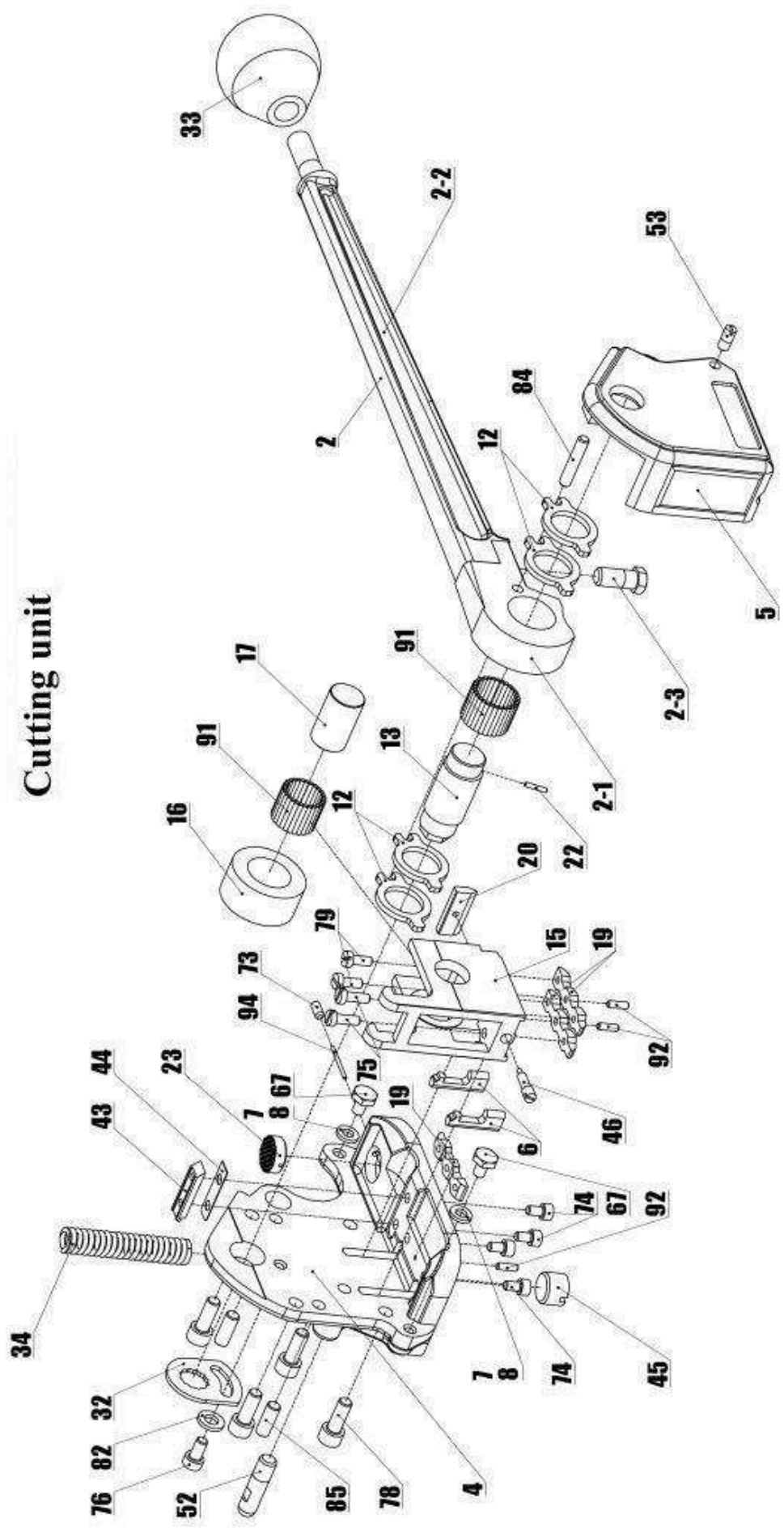

Operating instructions for mechanical for strapping (further in the text – tool) is designed for acquainting with the tool and principle of its operation. The instruction also contains information operator needs for proper operation of the tool.

1. PURPOSE

1.1. The tool can be used in various branches of industry in making up of freight units, particularly shipping bundles of lumber, sectional furniture, for packaging bricks, glass at the glassworks, steel framework, pipes, etc. It also can be used for fastening of crates.

1.2. Tool is intended for strapping of freight with steel strap width 1/2", 5/8", 3/4"
(13, 16, 19mm).

Thickness of strap should be:

- regular duty ($< 850 \text{ N/mm}^2$) up to 0,031" (0,8 mm);
- heavy duty ($< 1100 \text{ N/mm}^2$) up to 0,025" (0,63 mm).

1.3. The tool can be used inside as well as outside in all climatic zones.

2. TECHNICAL DATA

- 2.1. Strapping tape tension force, N.....up to 6000
- 2.2. Join strength at cross-section of the strap.....~80% of tape strength;
- 2.3. Overall dimensions, mm.....390x105x185
- 2.4. Weight, kg.....3.8

3. ARRANGEMENT OF THE TOOL

3.1. Principle of operation of the tool consists in tensioning the ends of the strap, winded around load, making self-sealing joint and cutting the free end of the strap.

3.2. The tool (Pic. 1) consists of tension unit and unit of forming the joint and cutting the strap (connecting unit). Tension unit includes Tension lever 1, Block wheel 29, Rocker lever 3, and Tension wheel 24, Toothed plate (bottom gripper) 23, Shaft 25, Plate 31 with Tension pawls 26, 28, 35 and Set screw 39. Tensioning wheel 24 in the tool is previously pressed to the strap by the Compressing spring 34.

Connecting unit consist of Housing 4 and Lid 5, Sealing lever 2, sealing block 15 with two Die 19 and cutting knife 20 on it. Retaliatory (lower) Die 19 is fastened to the Housing 4.

After making joint the strap is removed from the lower Die 19 by the Back up hoop 6.

The modifications of the tool could have some differences from the schematic list on pic. 1.

4. ADJUSTING THE TOOL

4.1. The tool is adjusted at the factory as a rule for the 0,5 mm thick and 16 mm wide strap. For customer's request it is possible to adjust the tool for the other strap thickness and width.

4.2. The necessity of adjusting the strap thickness you can evaluate from the quality of the cutting. The tool is set up properly if after interlocking the strap the upper strap is cut off cleanly and there are no marks from cutter on the lower strap.

4.3. Adjusting the tool is make up in the following way (Pic.2):

4.3.1. Loosen Cylinder screw 76.

4.3.2. Rotate Eccentric shaft 13 with Adjustment plate 32 at an angle of 20-25 degrees clockwise (is you watch Eccentric shaft 13 with line scribed on it) to adjust the tool for 0,82 mm thick strap; and counterclockwise if you want to adjust the tool for 0,3 mm thick strap

4.3.3. If necessary replace Adjustment plate 32 on the hex end of Eccentric shaft 13 a tight Cylinder screw 76.

4.4. To set up the unit according to the width of the used strap, carry out the following operations:

4.4.1. Please control, that on the places of front and back plates Screws 67 with necessary quantity of washers are set.

Width of the strap	Quantity of washers, pcs.	
	pos.7 (0,5mm)	pos.8 (1,5mm)
13	1	2
16	1	1
19	1	0
20	0	0

4.4.2. Cut the piece of the strap used for packing having length of 150 to 200 mm.

4.4.3. Tighten (clockwise) screw 49, in tie of Strap guide pawl 47, against the end of the strap and loosen by ½ turn, then lock it with the use of Screw 65 (Pic.3).

4.5. To adjust the clearance between the Tensioning wheel 24 and Toothed plate 23 loosen Screw 73 under the bolt and tight Set screw 39 (if you want to enlarge the clearance) or loosen it if you want to lessen the clearance. Tight the Screw 73. There must be 0,1-0,3 mm clearance between the Tensioning wheel 24 and Toothed plate 23. If thin strap is used the clearance should be set up closer to the lower limit (Pic.4).



Pic. 2



Pic. 3

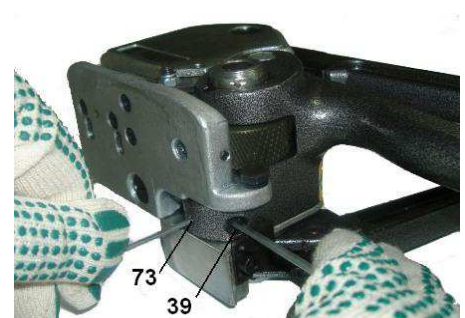

Pic.4

4.6. Tension lever 1 may have three initial positions: transport (lower) one, middle one and upper one. To choose the initial position of the tension handle that is most convenient for operation, screw out Cylinder screw 76 fixing Plate 51 and shift the latter in such a way that tension lever 1 thrusts against one of three extensions of Plate 51 and the tighten screw 76.

5. PREPARING OF UNIT FOR OPERATION

5.4. Prior to starting the operation of the unit, the operating and maintenance staff shall study this Manual.

5.5. Check conformity of the unit set-up to the used packing strap and set up the unit as per Section 4, if required.

6. ORDER TO WORK

6.4. Set up the tool on the horizontal surface of the item being packed with its levers 3, 4, and 5 inverted to you (Pic.6). It is possible to use the tool in vertical position.

6.5. Wind the strap around the packing item (strap from dispenser should be in the upper position). If precut strap is used, the upper end of the strap should be turned to you.

6.6. Putting your right hand on sealing lever 4, lift Rocker lever 3 up against the stop. By left hand, introduce the both ends of the strap into formed opening against flat heads of screws serving as front and rear strap guide. Lower Rocker lever 3 so that Screw 49 serving as a side strap guide contacts the end of the introduced strap with flat part of the head (Pic.5).



Pic. 5



Pic. 6

6.7. While retaining the unit by holding Sealing lever 4 in your left hand, tension the strap by shifting Tensioning lever 5 from Plate 51 to set screw 52. In this case, the force in the last stage of shifting the tensioning lever shall not be excessive to avoid rupture of the strap (Pic.6).

6.8. While retaining Tensioning lever 5, turn sealing lever “from you” against the stop and return it to the initial position (Pic.7).

6.9. Having put your right hand on the Sealing lever 4, lift Rocker lever 3, displace the product to the right and release the strap (Pic.8).



Pic.7



Pic.8

6.10. Check the visual inspection the quality of obtained “flat-scarf” connection of the strap.

Note 1: It is possible to re-tension a strapping provided earlier in case it became loose due to nature of the packed materials (during loss, compacting, etc.). For this purpose, while carrying out the original strapping, it is necessary to leave the end of the lower strap extending approximately by 150mm from the unit. Locate the unit before the original strapping in such a way that flat scarf is behind rear strap guide 67, and repeat steps described in Par. 6.3 to 6.7.

Note 2: for working with high tension steel straps and steel straps with high thickness (p. 1.2.), by additional order, tool can have in komplet elongator for sealer handle pos. 2-4 (pic. 9).



Pic. 9

7. MAINTENANCE REPAIR

7.4. The maintenance of the unit consist in periodical (before beginning of each working shift) removal of dirt and foreign particles from knives 19 and 20, as well as from teeth of tension roller 24 and 23.

7.5. With respect to the questions about getting you should tern to the factory of origin or to its official dealers.

8. STORAGE AND TRANSPORTATION RULES

8.4. The tool should be stored preserved indoor.

8.5. You can choose any method of transportation the tool. The tool should be packed in cartoon or woody box or warped with paraffin paper.

9. CUSTOMER ACCEPTANCE CERTIFICATE

Manufactured article M4K-12 serial No _____ declared suitable for using.

Data of production_____

S.P.

Signature_____

10. WARRANCY POLICY

10.4. The manufacturer guarantees perfect work of the tool during 2 years from the date of shipment if all operating rules are observed, except rubbing parts pos. 19, 20, 23, 24.

10.5. Guarantee repair is free and made by manufacture or manufacturer's representative at his place or at customer's place according to their agreement. Repair after expiration of guarantee term is made by manufacturer according to additional agreement.