

1) TOOL TYPE - GERAETETYP - DESCRIZIONE MACCHINA - TYPE D'OUTIL - TIPO DE MAQUINA
 cod. 11074 - 21074 - 31074 - P31074 1B 7C-16

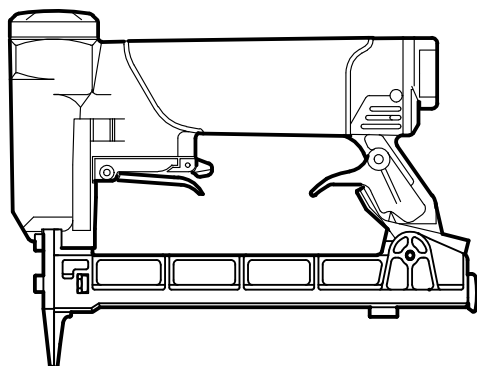

2) TOOL CHARACTERISTICS
 SPEZIFICATION DES GERAETES
 CARATTERISTICHE TECNICHE
 CARACTÉRISTIQUES DE L'OUTIL
 CARACTERÍSTICAS DE LA MAQUINA

HEIGHT HOEHE ALTEZZA HAUTEUR ALTURA	WIDTH BREITE LARGHEZZA LARGEUR ANCHURA	LENGTH LAENGE LUNGHEZZA LONGUEUR LONGITUD	WEIGHT GEWICHT PESO POIDS PESO
in.6.18 mm.157	in.1.65 mm.42	in.8.58 mm.218	lbs.1.71 kg.0.780
MIN-MAX WORKING PRESSURE MIN-MAX ARBEITSDRUCK MIN-MAX PRESSIONE DI ESERCIZIO MIN-MAX PRESSION DE TRAVAIL MIN-MAX PRESSION DE TRABAJO		60 / 100 PSIG 4 / 7 BAR	
AIR CONSUMPTION PER SHOT LUFTVERBRAUCH PRO NAGELUNG CONSUMO ARIA PER COLPO CONSOMMATION DE L'AIRE PAR COUP CONSUMO DE AIRE CADA DISPARO		PERFORMANCES AT 90 psi (0.62 MPa) PRESTAZIONI A 6.2 bar (0.62 MPa) 0.37 l.	
LUBRICANT SCHMIEROEL LUBRIFICANTE LUBRIFIANT LUBRIFICANTE		AEROSPACE LUBRICANTS TRIBOLUBE 12	

* ACTUATION SYSTEM * AUSLÖSEART * ATTUAZIONE * MISE EN ŒUVRE * ACTUACIÓN	1 (SAFETY : MANUAL)
--	---------------------

* SEE INSTRUCTION MANUAL - SIEHE BETRIEBSANLEITUNG - VEDI MANUALE - VOIR MODE D'EMPLOI - VER EL MANUAL

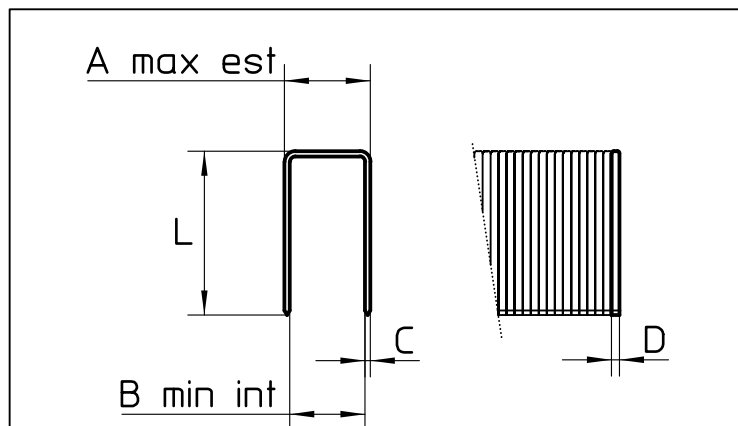

3) FASTENER DATA
 ANGABEN ZU DEN BEFESTIGUNGSMITTELN
 CARATTERISTICHE TECNICHE FISSAGGI
 DONNÉES DES PROJECTILES
 DATOS DE CLAVOS

A) OUTSIDE CROWN AUSSEN RUECKEN LARGHEZZA EST. COURONNE EXT. CORONA EXT.	MAX	in. 0.354 mm. 9.00
B) INSIDE CROWN INNEN RUECKEN LARGHEZZA INT. COURONNE INT. CORONA INT.	MIN	in. 0.303 mm. 7.70
CxD) WIRE DRAHT FILO FIL ALAMBRE		in. 0.023 x 0.029 mm. 0.60 x 0.75
L) LENGTH LAENGE LUNGHEZZA LONGUEUR LONGITUD	MIN-MAX	in. 1/4" - 5/8" mm. 6 - 16
MAGAZINE CAPACITY MAGAZIN CAPAZITAET CAPACITA' CARICATORE CAPACITE' CHARGEUR CAPACIDAD CARGADOR		180 staples

* LOADING * LADEN * CARICAMENTO * CHARGER * CARGA	<input checked="" type="radio"/> BOTTOM LOADING <input type="radio"/> SIDE LOADING <input type="radio"/> TOP LOADING <input type="radio"/> COIL <input type="radio"/> OTHER
---	---

NOISE CHARACTERISTICS GERÄUSCH - EMISSION DATEN CARATTERISTICHE RUMOROSITA' CARACTÉRISTIQUES ACOUSTIQUE CARACTERÍSTICAS DE RUIDO	EN 12549+A1:2008 EN ISO 4871:2009	$L_{WA,1s}$, :89.02 dB(A) - $K_{WA,1s}$, 2.5 $L_{pA,1s}$, :79.70 dB(A) - $K_{pA,1s}$, 2.5
--	--------------------------------------	--

VIBRATION VALUE VIBRATIONSWERT VALORE DI VIBRAZIONE VALEUR DE VIBRATION VALOR DE VIBRACIÓN	UNI ISO/TS 8662-11	IS BELOW THE DECLARATION LIMIT SET BY LIEGT UNTER DEM ANZUGEBENEN WERT GEMÄSS RISULTA AL DI SOTTO DEL LIMITE DA DICHI. STABILITO IN RESULTE AU DESSOUS DE LA LIMITE A DECLARER ETABLIE PAR RESULTA SER DEBAJO DEL LIMITE A DECLARAR	UNI EN ISO 12100-1/2
--	-----------------------	---	-------------------------